



## CSE Auto control Actuator

### Concept 概念：

氣動頭的執行機構和調節機構是統一的整體，其執行機構有活塞式和齒輪齒條式。活塞式行程長，適用於要求有較大推力的場合；由於齒輪齒條式氣動執行機構有結構簡單，輸出推力大，動作平穩可靠優點，對安全要求較高的生產過程中有廣泛的套用。

The actuator and adjustment mechanism of the pneumatic head are a unified whole, and the actuator has a piston type and a rack and pinion type. The piston type has a long stroke and is suitable for occasions that require greater thrust; because the rack and pinion pneumatic actuator has the advantages of simple structure, large output thrust, stable and reliable action, it is widely used in the production process with high safety requirements.

### Working principle 工作準則

The working principle of the cylinder is to use compressed air as the power source. When the compressed air source enters the cylinder cavity, it pushes the cylinder piston. Depending on the inlet and outlet holes, the piston moves toward the cylinder head at both ends or moves toward the center. The piston moves in conjunction with the crank arm and the shaft center, the piston action makes the shaft center rotate 90 degrees and the shaft center in the cylinder rotates at the same time to drive the valve connected below, so that the valve can achieve the effect of opening and closing and control.

氣缸的工作原理是利用壓縮空氣作為動力來源，當壓縮氣源進入到氣缸腔內時來推動氣缸活塞根據進出氣孔的不同，活塞會往兩端氣缸蓋或者往中心方向做活塞運動活塞則連動著曲臂和軸心，活塞動作使軸心作 90 度旋轉氣缸內軸心旋轉同時帶動下方連結的閥門，進而使閥門達到啟閉、控制的效果。

### Standard design 標準設計

#### Single-acting cylinder

The inside of a single-acting cylinder uses a spring to make the piston rebound. The piston is pushed to both ends of the cylinder head. At this time, the spring in the cylinder is in a compressed state. When the air supply is interrupted, the spring force pushes the piston back to the center of the cylinder, so under normal circumstances, the main function of a single-acting cylinder is to open the valve when the air is input, and the spring will return when the air supply is interrupted, and the valve will be closed automatically.

#### Double-acting pneumatic actuator:

When compressed air enters the pneumatic actuator from the A nozzle, the gas pushes the double piston to move linearly to both ends (cylinder head end). The rack on the piston drives the gear on the rotating shaft to rotate 90 degrees counterclockwise, and the valve is opened. At this time, the gas at both ends of the pneumatic actuator valve is discharged with the B nozzle. Conversely, when compressed air enters the two ends of the pneumatic actuator from the B nozzle, the gas pushes the double plug to move linearly in the middle, and the rack on the piston drives the gear on the rotating shaft to rotate 90 degrees clockwise, and the valve is closed. At this time, the gas in the middle of the pneumatic actuator is discharged with the A nozzle. The above is the standard transmission principle. At the same time, according to the demand, the pneumatic actuator can also be installed with the transmission principle opposite to the standard type, that is, the clockwise rotation of the collimator shaft is selected to open the valve, and the counterclockwise rotation is to close the valve.

#### 單動式氣缸

單動式氣缸內部是利用彈簧使活塞坐回彈的動作，活塞分別向汽缸蓋的兩端推去，此時氣缸內的彈簧處於壓縮狀態，而當氣源中斷時，彈簧的彈力將活塞推回氣缸中心，所以一般情況下的單動氣缸最主要的功能就是當氣員輸入時閥門開啟而當氣源中斷時彈簧則復歸，自動將閥門關閉。

雙作用氣動執行器：

當壓縮空氣從 A 管咀進入氣動執行器時，氣體推動雙活塞向兩端(缸蓋端)直線運動，活塞上的齒條帶動旋轉軸上的齒輪逆時針方向轉動 90 度，閥門即被打開。此時氣動執行閥兩端的氣體隨 B 管咀排出。反之，當壓縮空氣從 B 管咀進入氣動執行器的兩端時，氣體推動雙塞向中間直線運動，活塞上的齒條帶動旋轉軸上的齒輪順時針方向轉動 90 度，閥門即被關閉。此時氣動執行器中間的氣體隨 A 管咀排出。以上為標準型的傳動原理。同時根據需求，氣動執行器也可裝置成與標準型相反的傳動原理，即選準軸順時針方向轉動為開啟閥門，逆時針方向轉動為關閉閥門。

Parts List			
Item	Parts name	Q'TY	Material
1	PT 1/8" Air Connection	1	Copper
2	St.St Cylinder Cap	1	ST.ST 304
3	Piston	1	POM
4	Piston O-Ring	1	NBR70(Block)
5	St.St Cylinder	1	ST.ST 304
6	Compress Spring	4	ST.ST 304
7	Coupling Axle Piece	1	ST.ST 303
8	Teflon gasket	3	Teflon
9	φ11 Piston guide part	3	ST.ST 304
10	φ13 Piston guide part	1	ST.ST 304
11	φ12 Piston guide part	2	ST.ST 304
12	φ70 O-Ring	1	NBR70(Block)
13	φ21.7 O-Ring	1	NBR70(Block)
14	Lower Cylinder End	1	ST.ST 304
15	Lock Wire Clip	1	ST.ST 304
16	Contact Seal	1	ST.ST 304
17	φ15 Cir Clip	1	ST.ST 304
18	Connection piece	1	ST.ST 304
19	Mounting bracket	1	ST.ST 304
20	M8x12 ST.ST Screw	2	ST.ST 304
21	Muffler	1	Copper
22	Gasket	4	ST.ST 304
23	M6 ST.ST NUT	2	ST.ST 304
24	M6x35 ST.ST Screw	2	ST.ST 304
25	Piston cover	1	ST.ST 303/304

Material :

Other steel : AISI304

Other seal : NBR

Technical data :

Air pressure : 5 to 9 bar

operating air pressure : 6kg/cm<sup>2</sup>

shut-off time : 1.5 second

air consumption : 0.266 liter at 5 bar

Temperature :

Range : -10°C ~ +100°C

# C2

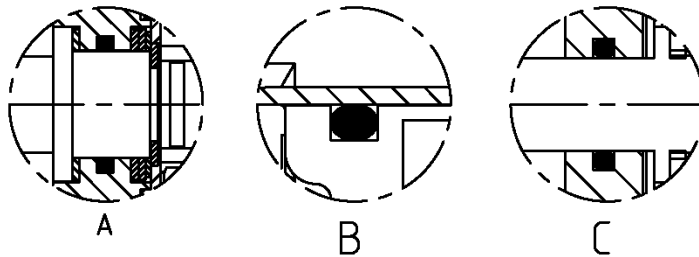
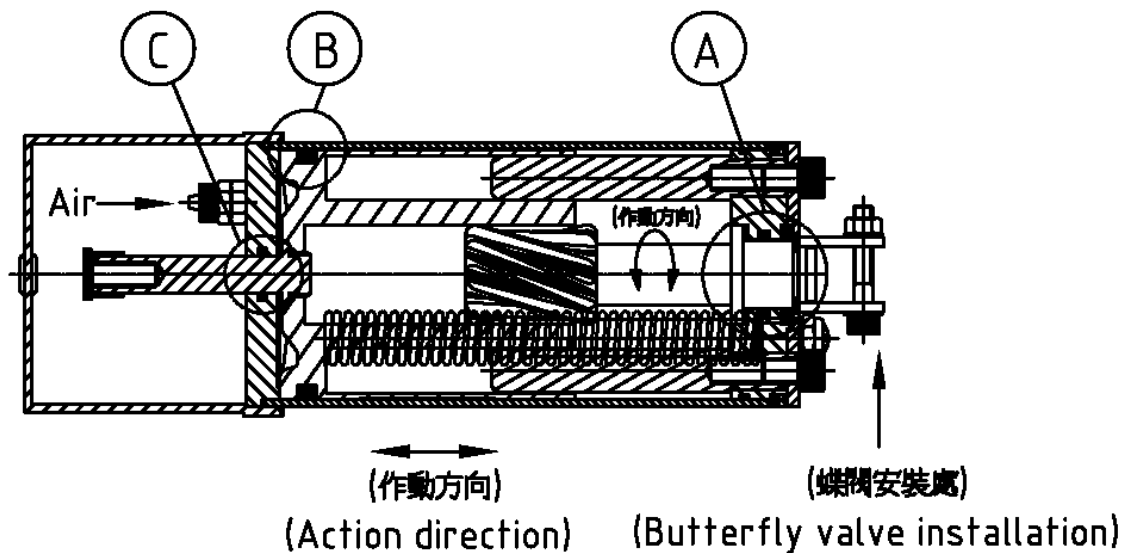

## Mechanical principle 作動原理

The gas flows into the cylinder to drive the central axis and spring of piston moving up and down, and further transmitting the screw to move.

氣缸進入缸內帶動活塞中心軸及彈簧上下往覆作動，使螺桿旋轉。

## Precautions 注意事項：

- 1、 Site A is for the friction between the central axis and the cylinder head.
- 2、 Site B is for the friction between the piston and the cylinder wall.
- 3、 Site C is for the friction between the rod and the cylinder bottom cover, and spring compression, will be up and down because of reciprocating action to produce heat.
- 4、 This product can not be applied for mining.

- 1、 A 處為中心軸與氣缸蓋摩擦。
- 2、 B 處為活塞與氣缸壁摩擦。
- 3、 C 處則是支桿和氣缸底蓋摩擦，及彈簧壓縮，會因上下往覆作動而產生熱能。
- 4、 D 不適用於礦坑內使用。

# C3

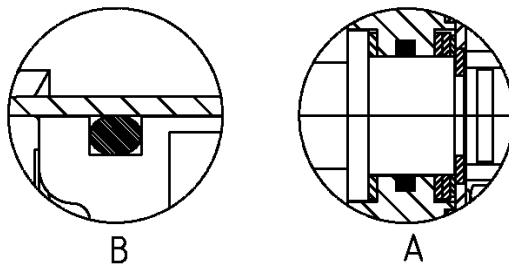
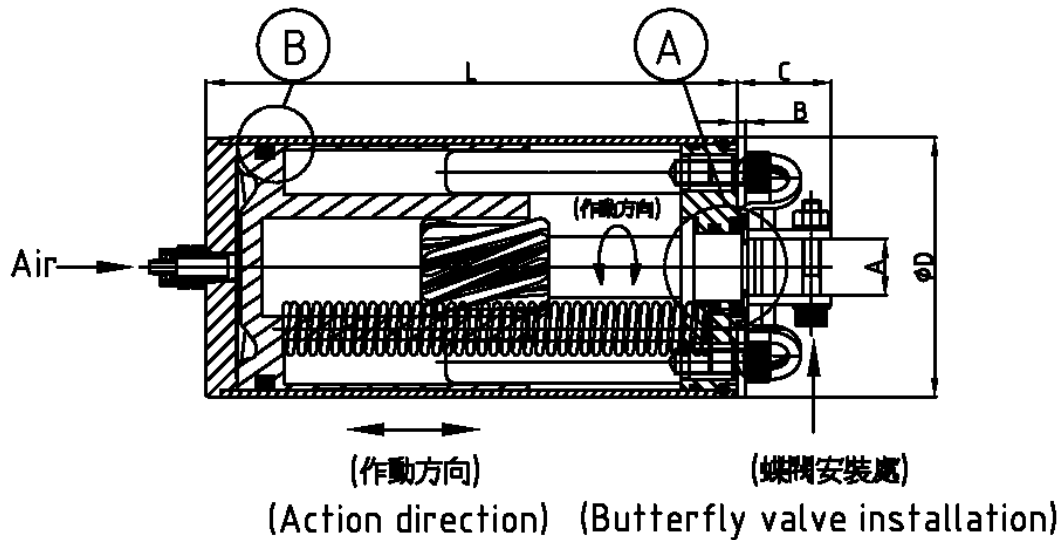

## Mechanical principle 作動原理

The gas flows into the cylinder to drive the central axis and spring of piston moving up and down, and further transmitting the screw to move.

氣缸進入缸內帶動活塞中心軸及彈簧上下往覆作動，使螺桿旋轉。

## Precautions 注意事項：

- 1、Site A is for the friction between the screw and the guiding set.
- 2、Site B is for the friction between the piston and the cylinder wall. Heat can be generated due to the action of spring.
- 3、C this product can not be applied for mining.

- 1、A 處為螺桿與引導作摩擦。
- 2、B 處為活塞與氣缸壁摩擦及彈簧壓縮會因上下往覆作動而產生熱能。
- 3、C 不適用於礦坑內使用。

# C101

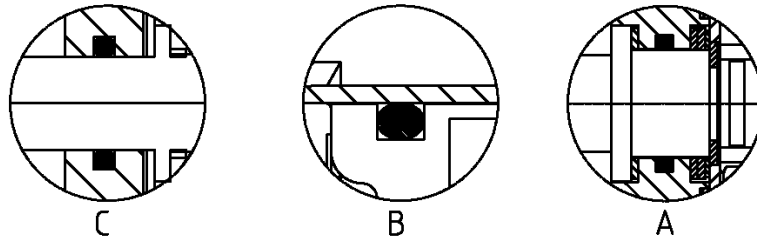
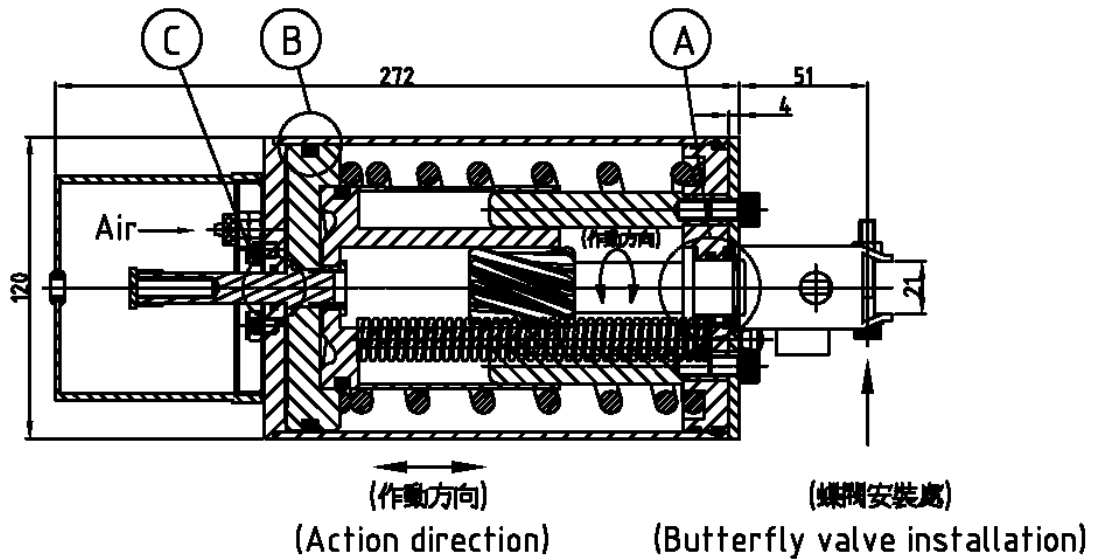

## Mechanical principle 作動原理

The gas flows into the cylinder to drive the central axis and spring of piston moving up and down, and further transmitting the screw to move.

氣缸進入缸內帶動活塞中心軸及彈簧上下往覆作動，使螺桿旋轉。

## Precautions 注意事項：

- 5、 Site A is for the friction between the central axis and the cylinder head.
- 6、 Site B is for the friction between the piston and the cylinder wall.
- 7、 Site C is for the friction between the rod and the cylinder bottom cover, and spring compression, will be up and down because of reciprocating action to produce heat.
- 8、 This product can not be applied for mining.

- 4、 A 處為中心軸與氣缸蓋摩擦。
- 5、 B 處為活塞與氣缸壁摩擦。
- 6、 C 處則是支桿和氣缸底蓋摩擦，及彈簧壓縮，會陰上下往覆作動而產生熱能。
- 4、 D 不適用於礦坑內使用。